



Lesite Technology

# Plastic Extrusion Welder

LST600A/B/C

LST610A/B/C

LST600E/600F/610E

LST620

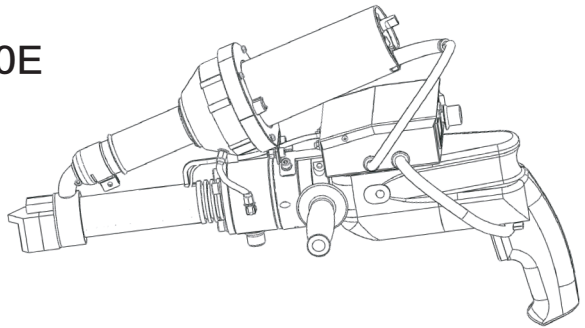

## Manual

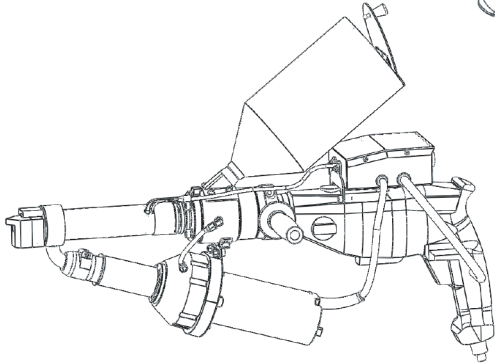
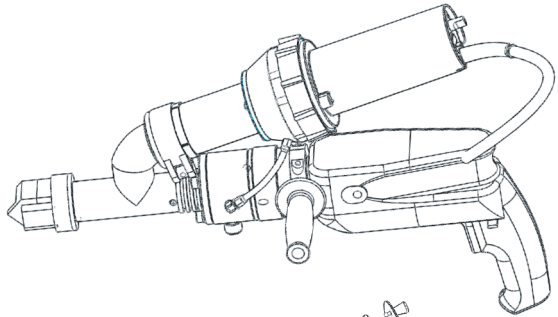



**Please read this manual carefully before using this machine, and keep it for future reference**

Each plastic extrusion welder must undergo a double test of 100% performance and safety before leaving the factory.

## Application

Used for welding thermoplastic materials PE and PP (sheet + film material) in the following fields:

Container Fabrication

Piping Fabrication

Electroplating Anti-corrosion Equipment

Landfill

Repair of Geomembrane

Environmental Protection Equipment



## Precautions



Please confirm that the machine is turned off and unplugged before disassembling the welding machine so as not to be injured by live wires or components inside the machine.



The welding machine generates high temperature and high heat, which may cause fire or explosion when used incorrectly, especially when it is close to combustible materials or explosive gas.



Please do not touch the air duct and nozzle(during welding work or when the welding machine has not completely cooled down), and do not face the nozzle to avoid burns.



The power supply voltage must match the rated voltage marked on the welding machine and be reliably grounded. Connect the welding machine to a socket with a protective ground conductor.



In order to ensure the safety of the operators and the reliable operation of the equipment, the power supply at the construction site must be equipped with a regulated power supply and a leakage protector.



The welding machine must be operated under the correct control of the operator, otherwise it may cause combustion or explosion due to high temperature.



It is strictly forbidden to use the welding machine in water or muddy ground, avoid soaking, rain or damp.

Product Series

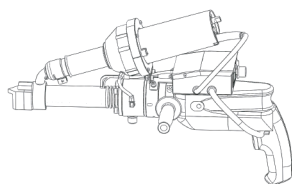

LST600A

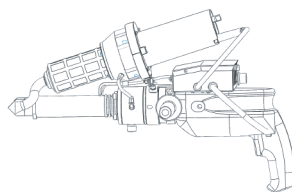

LST600B

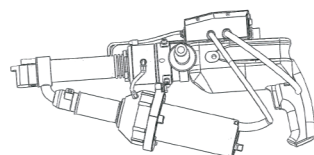

LST600C

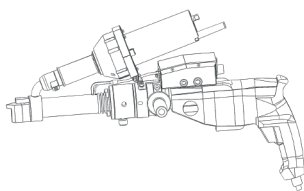

LST610A

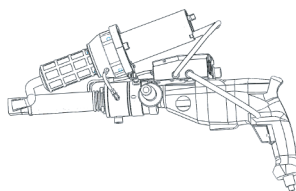

LST610B

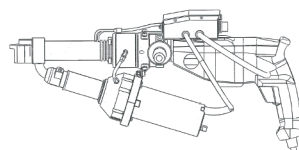

LST610C

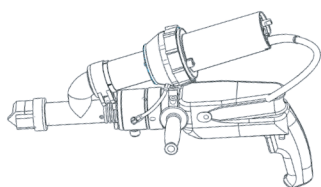

LST600E

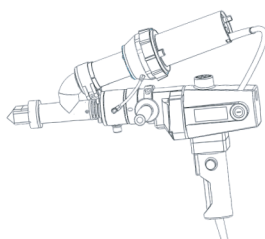

LST600F

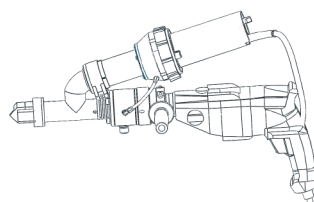

LST610E

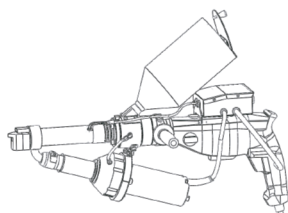

LST620

## Dual Heating Extrusion Welder Parameter

Model	<b>LST600A</b>	<b>LST600B</b>
Rated Voltage	230 V	230 V
Frequency	50 / 60 Hz	50 / 60 Hz
Extruding Motor Power	800 W	800 W
Hot Air Power	1600 W	3400 W
Welding Rod Heating Power	800 W	800 W
Hot Air Temperature	20 – 620°C	20 – 620°C
Plastic Extruding Temperature	50 – 380°C	50 – 380°C
Extruding Volume	2.0–2.5 Kg/h	2.0–2.5 Kg/h
Welding Rod Diameter	φ3.0–4.0mm	φ3.0–4.0mm
Net Weight	6.9 Kg	6.9 Kg
Driving Motor	HIKOKI	HIKOKI
Digital Display	Extruding Temperature	Extruding Temperature
Trouble Display	Code Warning	Code Warning
Certificate	CE	CE
Warranty	1 year	1 year

Model	<b>LST600C</b>
Rated Voltage	230 V
Frequency	50 / 60 Hz
Extruding Motor Power	800 W
Hot Air Power	1600 W
Welding Rod Heating Power	800 W
Hot Air Temperature	20 – 620°C
Plastic Extruding Temperature	50 – 380°C
Extruding Volume	2.0–2.5 Kg/h
Welding Rod Diameter	φ3.0–4.0mm
Net Weight	6.9 Kg
Driving Motor	HIKOKI
Digital Display	Extruding Temperature
Trouble Display	Code Warning
Certificate	CE
Warranty	1 year

## Dual Heating Extrusion Welder Parameter

Model	<b>LST610A</b>	<b>LST610B</b>
Rated Voltage	230 V	230 V
Frequency	50 / 60 Hz	50 / 60 Hz
Extruding Motor Power	1300 W	1300 W
Hot Air Power	1600 W	3400 W
Welding Rod Heating Power	800 W	800 W
Hot Air Temperature	20 – 620°C	20 – 620°C
Plastic Extruding Temperature	50 – 380°C	50 – 380°C
Extruding Volume	2.0–3.0 Kg/h	2.0–3.0 Kg/h
Welding Rod Diameter	φ3.0–4.0mm	φ3.0–4.0mm
Net Weight	7.2 Kg	7.2 Kg
Driving Motor	METABO	METABO
Digital Display	Extruding Temperature	Extruding Temperature
Trouble Display	Code Warning	Code Warning
Certificate	CE	CE
Warranty	1 year	1 year

Model	<b>LST610C</b>
Rated Voltage	230 V
Frequency	50 / 60 Hz
Extruding Motor Power	1300 W
Hot Air Power	1600 W
Welding Rod Heating Power	800 W
Hot Air Temperature	20 – 620°C
Plastic Extruding Temperature	50 – 380°C
Extruding Volume	2.0–3.0 Kg/h
Welding Rod Diameter	φ3.0–4.0mm
Net Weight	7.2 Kg
Driving Motor	METABO
Digital Display	Extruding Temperature
Trouble Display	Code Warning
Certificate	CE
Warranty	1 year

## Main Parts

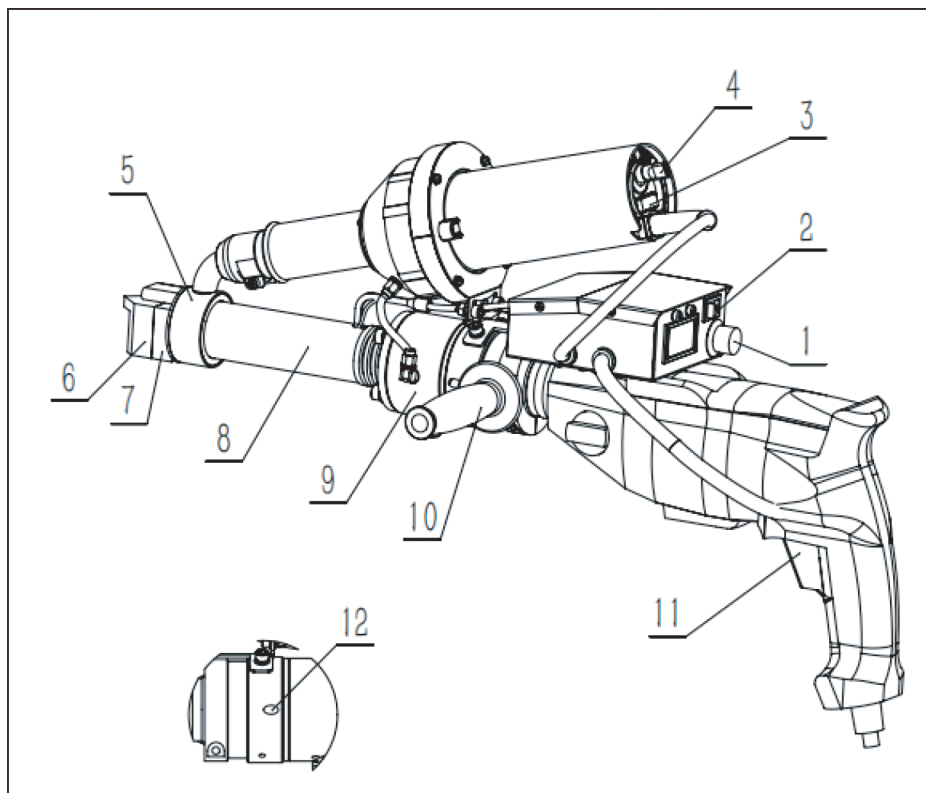

- |                                       |                                |
|---------------------------------------|--------------------------------|
| 1、Control Box Temperature Adjust Knob | 2、Control Box Power Switch     |
| 3、Hot Air Blower Power Switch         | 4、Hot Air Blower Potentiometer |
| 5、Hot Air Scooper                     | 6、Welding Shoe                 |
| 7、Welding Shoe Aluminum Base          | 8、Temperature Storage Tube     |
| 9、Flange                              | 10、Handle                      |
| 11、Drive Motor Switch                 | 12、Welding Rod Feeding Inlet   |

## Dual Heating Extrusion Welder Operating steps

### ◆ Power on

- 1、 Plug in
- 2、 Press the control box power switch and rotate the control box temperature adjust knob to 320-350°C (Digital Display)
- 3、 When the digital display temperature reaches setting temperature, delay 180 seconds before starting the drive motor (cold start protection)

### ◆ Preparation before welding

- 1、 Turn on the hot air blower power switch, rotate the hot air blower potentiometer to position 6-7
- 2、 Clean the welding rod surface and insert it into the feeding inlet
- 3、 Press the drive motor switch ( short contact 2-3 seconds). After repeating 2-3 times, confirm the sound of the drive motor is normal and the speed of welding rod extrusion is smooth (Extend the heating time if the sound is abnormal or welding rod is not extruded)
- 4、 The extruded welding rod is not soft or hard, and the smooth surface luster is the best extruding effect
- 6、 Start Welding

### ◆ Notes for welding process

- 1、 If the sound of the drive motor suddenly changes or the welding rod is stuck without feeding, it is necessary to immediately loosen the drive motor switch and check whether the heating temperature is normal
- 2、 In the case of no welding rod feeding in, immediately release the drive motor switch. Do not start the drive motor without welding rod

### ◆ Turn off steps

- 1、 The plastic in the extruder must be cleaned before the machine is turned off so as not to cause blockage and damage the extruder next time
- 2、 After cleaning plastic, set the hot air blower potentiometer to 0 and cool it down
- 3、 Turn off the hot air blower power switch
- 4、 Turn off the control box power switch
- 5、 Cut off the power



Use fireproof mats



Don't direct hot air towards people or objects

## Single Heating Extrusion Welder Parameter

Model	<b>LST600E</b>	<b>LST600F</b>
Rated Voltage	230 V	230 V
Frequency	50 / 60 Hz	50 / 60 Hz
Extruding Motor Power	800 W	1200 W
Hot Air Power	3400 W	3400 W
Welding Rod Heating Power	/	/
Hot Air Temperature	20 – 620°C	20 – 620°C
Plastic Extruding Temperature	/	/
Extruding Volume	2.0–2.5 Kg/h	2.5–3.0 Kg/h
Welding Rod Diameter	φ3.0–4.0 mm	φ3.0–4.0 mm
Net Weight	6.0 Kg	7.5 Kg
Driving Motor	HIKOKI	FEIJI
Certificate	CE	CE
Warranty	1 year	1 year

Model	<b>LST610E</b>
Rated Voltage	230 V
Frequency	50 / 60 Hz
Extruding Motor Power	1300 W
Hot Air Power	3400 W
Welding Rod Heating Power	/
Hot Air Temperature	20 – 620°C
Plastic Extruding Temperature	/
Extruding Volume	2.5–3.0 Kg/h
Welding Rod Diameter	φ3.0–4.0 mm
Net Weight	6.3 Kg
Driving Motor	METABO
Motor Overload Protection	Default
Certificate	CE
Warranty	1 year



## Main Parts

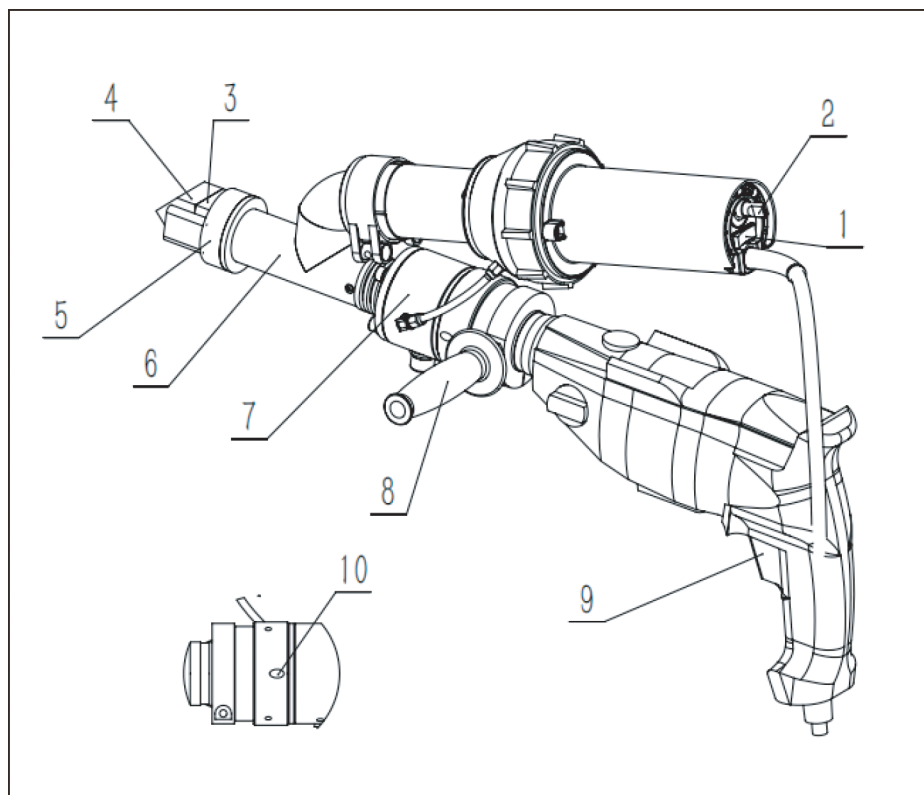

- 1、 Hot Air Blower Power Switch
- 3、 Welding Shoe Aluminum Base
- 5、 Hot Air Scooper
- 7、 Flange
- 9、 Drive Motor Switch

- 2、 Hot Air Blower Potentiometer
- 4、 Welding Shoe
- 6、 Temperature Storage Tube
- 8、 Handle
- 10、 Welding Rod Feeding Inlet

## Single Heating Extrusion Welder Operating Steps

### ◆ Power on

- 1、 Plug in
- 2、 Turn on the hot air blower power switch
- 3、 Rotate the hot air blower potentiometer to position 6-7
- 4、 After waiting for 9 minutes to complete the preheating, prepare to insert the welding rod

### ◆ Preparation before welding

- 1、 Clean the welding rod surface and insert it into the feeding inlet
- 2、 Press the drive motor switch ( short contact 2-3 seconds). After repeating 2-3 times, confirm the sound of the drive motor is normal and the speed of welding rod extrusion is smooth (Extend the heating time if the sound is abnormal or welding rod is not extruded)
- 3、 The extruded welding rod is not soft or hard, and the smooth surface luster is the best extruding effect
- 4、 Start Welding

### ◆ Notes for welding process

- 1、 If the sound of the drive motor suddenly changes or the welding rod is stuck without feeding, it is necessary to immediately loosen the drive motor switch and check whether the heating temperature is normal
- 2、 In the case of no welding rod feeding in, immediately release the drive motor switch. Do not start the drive motor without welding rod

### ◆ Turn off steps

- 1、 The plastic in the extruder must be cleaned before the machine is turned off so as not to cause blockage and damage the extruder next time
- 2、 After cleaning plastic, set the hot air blower potentiometer to 0 and cool it down
- 3、 Turn off the hot air blower power switch
- 4、 Cut off the power



Use fireproof mats



Don't direct hot air towards people or objects

## Granules Extrusion Welder

Model	<b>LST620</b>
Rated Voltage	230 V
Frequency	50 / 60 Hz
Extruding Motor Power	1300 W
Hot Air Power	1600 W
Granules Heating Power	800 W
Air Temperature	20 – 620°C Adjustable
Plastic Extruding Temperature	50 – 380°C Adjustable
Extruding Volume	2.0–3.5 kg/h
Net Weight	8.0 Kg
Driving Motor	METABO
Certificate	CE
Warranty	1 year

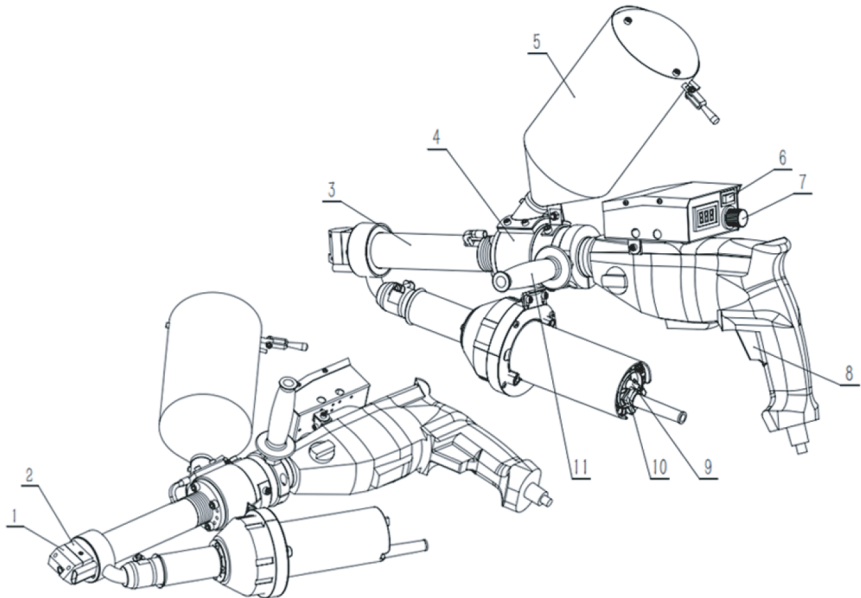

- |                                       |                                |                            |
|---------------------------------------|--------------------------------|----------------------------|
| 1、Welding Shoe                        | 2、Welding Shoe Aluminum Base   | 3、Temperature Storage Tube |
| 4、Flange                              | 5、Hooper                       | 6、Control Box Power Switch |
| 7、Control Box Temperature Adjust Knob | 8、Drive Motor Switch           |                            |
| 9、Hot Air Blower Potentiometer        | 10、Hot Air Blower Power Switch | 11、Handle                  |

## Granules Extrusion Welder Operating Steps

### ◆ Power on

- 1、 Plug in
- 2、 Press the control box power switch and rotate the control box temperature adjust knob to 320-350°C (Digital Display)
- 3、 When the digital display temperature reaches setting temperature, delay 180 seconds before starting the drive motor (Cold Start Protection)

### ◆ Preparation before welding

- 1、 Turn on the hot air blower power switch, rotate the hot air blower potentiometer to position 6-7
- 2、 Pour plastic granules into the hooper
- 3、 Press the drive motor switch and press the self-locking button, Confirm the sound of the drive motor is normal and the speed of granules extrusion is smooth (Extend the heating time if the sound is abnormal or granules is not extruded)
- 4、 The extruded granules is not soft or hard, and the smooth surface luster is the best extruding effect
- 5、 Start Welding

### ◆ Notes for welding process

- 1、 If the sound of the drive motor suddenly changes or the granules is stuck without feeding, it is necessary to immediately loosen the drive motor switch and check whether the heating temperature is normal
- 2、 In the case of no granules feeding in, immediately release the drive motor switch. Do not start the drive motor without granules

### ◆ Turn off steps

- 1、 The plastic in the extruder must be cleaned before the machine is turned off so as not to cause blockage and damage the extruder next time
- 2、 After cleaning plastic, set the hot air blower potentiometer to 0 and cool it down
- 3、 Turn off the hot air blower power switch
- 4、 Turn off the control box power switch
- 5、 Cut off the power



Use fireproof mats



Don't direct hot air towards people or objects

## Replacement of Welding Shoe



Scalding danger



Work only with heat-proof gloves



Turn off equipment and power off

### · Remove

- 1、 Remove the welding shoe with base from the extruder nozzle by loosening the tightening screws (1)
- 2、 For each replacement, the residue in the welding shoe must be cleaned and the extruder nozzle must be tightened
- 3、 Remove the welding shoe PTFE (4) from the welding shoe aluminum base (3) by loosening fastening screws (2)

### · Assembly

- 1、 Use the fastening screws (2) to install a welding shoe PTFE (4) on welding shoe aluminum base (3)
- 2、 Welding shoe PTFE (4) must be tightened with fastening screws (2) and tightening screws (1)

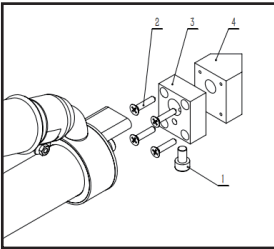

1. Tightening Screws
2. Fastening Screws
3. Welding Shoe Aluminum Base
4. Welding Shoe PTFE

## Direction of Welding Shoe

By loosening the tightening screws, the welding shoe can be rotated to the required welding direction. The tightening screws must be retightened.

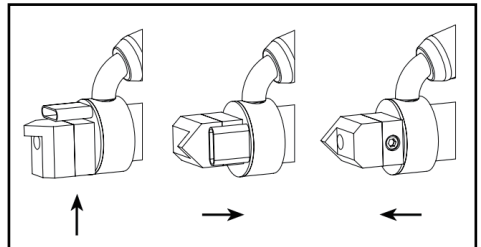

## Replacement of Heating Element

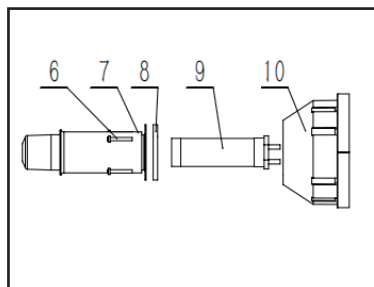
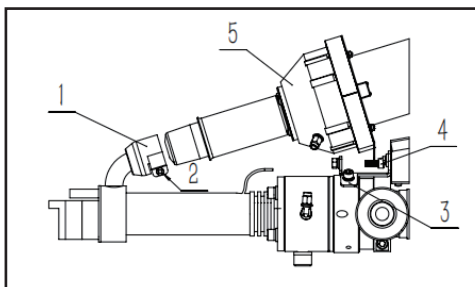

- 1、 Hot Air Blower Connector    2、 Long Hex Socket Screw    3、 Hot Air Blower Bracket
- 4、 Long Hex socket Screw    5、 Hot Air Blower    6、 Long Philips Screw
- 7、 Air Duct    8、 High Temperature Gasket    9、 Heating Element
- 10、 Outer Cover

### · Remove

Loosen the long hex socket screw (2) on the hot air blower connector (1) and the long hex socket screw (4) on the hot air blower bracket (3) to remove the hot air blower (5) from the plastic extrusion welder

Loosen the long Phillips screw (6) of the hot air blower and remove the air duct (7) and the high temperature gasket (8) from the outer cover (10)

Slowly remove the heating element (9) from the outer cover (10)

### · Assembly

Install the new heating element (9) in the outer cover (10)

Cover the high temperature gasket (8) and air duct (7) in order and lock them with the long philips screw (6)

Install the hot air blower (5) in the plastic extrusion welder and fix it with the tighten long hex socket screw(2) and the long hex socket screw (4)

## Replacement of Drive Motor

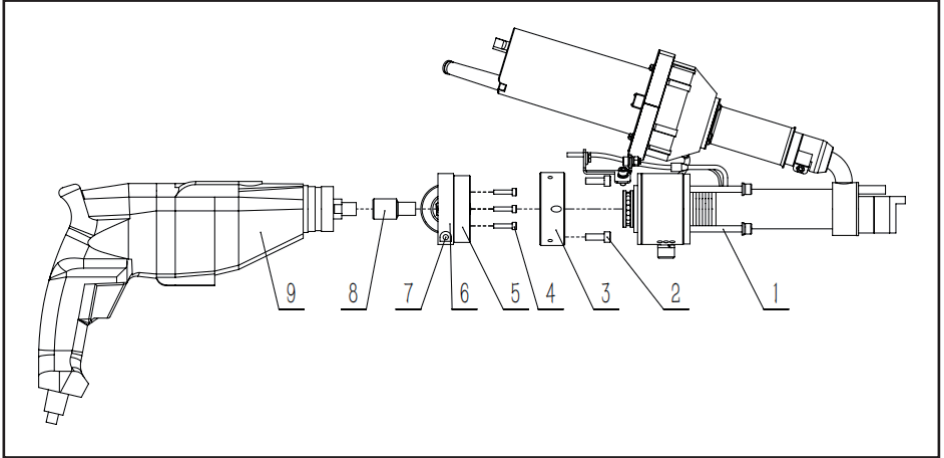

- |                      |                               |                       |
|----------------------|-------------------------------|-----------------------|
| 1、Fastening Bolt (A) | 2、Fastening Bolt (B)          | 3、Thrust Bearing Seat |
| 4、Fastening Bolt (C) | 5、Drive Motor Connecting Seat | 6、Handle Fixing Ring  |
| 7、Fastening Bolt (D) | 8、Connecting Nut              | 9、Drive Motor         |

### · Remove

Loosen the fastening bolt (A) (1), remove the thrust bearing seat (3) and the drive motor (9) in order

Loosen the fastening bolt (B)(2) and remove the thrust bearing seat (3) from the drive motor connecting seat (5)

Once loosening fastening bolt (C) (4) and fastening bolt (D) (7), remove the connecting seat (5) of the drive motor (9) and the handle fixing ring (6) from the drive motor (9)

Loosen the connecting nut (8) and remove the drive motor (9)

### · Assembly

Screw the connecting nut (8) to the new drive motor (9)

Using fastening bolt(C)(4) and fastening bolt(D)(7) to fix the connecting seat (5) and handle fixing ring (6) to the drive motor (9)

Using fastening bolt (B)(2) to fix the thrust bearing seat (3) to the connecting seat (5)

Install and fix the thrust bearing seat (3) and drive motor (9) by using fastening bolt (A)(1)

## Fault Code

Model	Fault Phenomenon	Fault Checking
LST610A/B/C/E LST600A/B/C/E/F	Plug in without any action	Check whether the input power supply and power cord are in good condition
LST610A/B/C LST600A/B/C LST620	Hot air blower is working properly but control box display is off	Check control box switch Check fuse of control box Check high-voltage protective varistor
LST610A/B/C/E/F LST600A/B/C/E/F LST620	Hot air blower does not work but control box is working properly	Check whether the connection between the hot air blower and the control box is in good condition Check whether the hot air blower power switch is damaged Check whether the carbon brush of hot air blower motor is depleted Check whether the motor is burned out
LST610A/B/C/E/F LST600A/B/C/E/F LST620	Hot air blower does not heat up	Check whether the heating element is damaged Check whether the potentiometer of air blower is damaged
LST610A/B/C LST600A/B/C LST620	The control box appears ok but can not heat up	Check whether the spring heating coil is damaged
LST610A/B/C/E LST620	The drive motor fault lamp flashes slowly	The motor carbon brush is depleted and the carbon brush needs to be replaced.



## Fault Code

Model	Fault Phenomenon	Fault Checking
LST610A/B/C/E LST620	The drive motor fault lamp flashes fastly	The power supply is in poor contact or the power cord is damaged
LST610A/B/C/E LST620	The drive motor fault lamp keeps on	Drive motor overtemperature problem
LST610A/C LST600A/C LST620	Error code ER1	The spring heating coil thermocouple has problem
LST610A/B/C LST600A/B/C LST620	Error code ER2	The spring heating coil is overtemperature
LST600A/B/C LST620	Error code ER3	Drive motor overtemperature problem
LST600A/B/C LST620	Error code ER4	The drive motor thermocouple has problem

## Maintenance

Clean all parts regularly to keep the whole machine clean

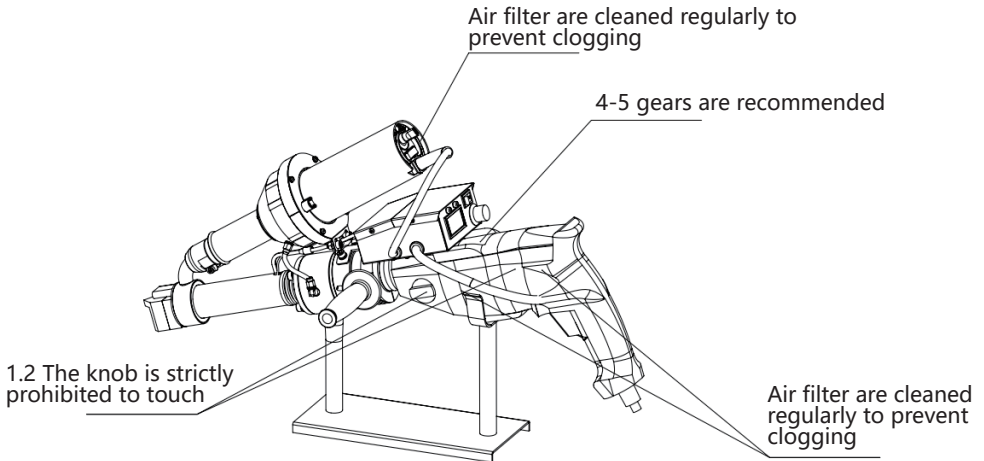

- The air filter should be cleaned with a brush when soiled
- For each replacement of welding shoe, clean the extruder nozzle and remove welding residue
- Check power connection and plug for breakage or mechanical damage
- The air duct should be cleaned regularly
- Repairs can only be carried out by professional Lesite service station to ensure professional and reliable maintenance service within 24 hours according to circuit diagram and spare parts list

## Warranty

- This product guarantees a 12-month liability period from the day it is sold to consumers. We will be responsible for failures caused by material or manufacturing defects. We will repair or replace defective parts at our sole discretion to meet the warranty requirements.
- The quality assurance does not include damage to wearing parts (heating elements, carbon brushes, bearings, etc.), damage or defects caused by improper handling or maintenance, and damage caused by falling products. Irregular use and unauthorized modification should not be covered by the warranty.

## Maintenance

- It is strongly recommended to send the product to Lesite company or authorized repair center for professional inspection and repair.
- Only original Lesite spare parts are allowed.





## FUZHOU LESITE PLASTICS WELDING TECHNOLOGY CO.,LTD



Tel: +86(591)83818890



E-mail: [info@lesite.com.cn](mailto:info@lesite.com.cn)

Web: [www.lesiteweld.com](http://www.lesiteweld.com)



Add: 5# Jingpu Road, Pushang Industry Park,  
Cangshan, Fuzhou, 350007, Fujian, China